



Please read this manual before operating

# UDS-N1/N2 ULTRASONIC SCALER INSTRUCTION MANUAL



[www.glwoodpecker.com](http://www.glwoodpecker.com)

**GUILIN WOODPECKER MEDICAL INSTRUMENT CO., LTD.**

## Contents

1. The installation and components of equipment .....	1
2. Product function and usage .....	4
3. Sterilization and maintenance .....	7
4. Notice .....	10
5. After-service .....	12
6. Environmental Protection .....	12
7. European authorized representative .....	12
8. Manufacturer's right .....	12
9. Symbol instruction .....	12
10. EMC - Declaration of conformity .....	13
11. Statement .....	16
TABLE OF OPERATING POWER OF THE TIPS.....	17

## **1. The installation and components of equipment**

### 1.1 Instruction

The “Woodpecker” built-in ultrasonic scaler UDS-N1 and UDS-N2 made in Guilin Woodpecker Medical Instrument Co., Ltd. are used along with dental unit for teeth cleaning. They are also indispensable equipments for teeth disease prevention and treatment.

### 1.2 Components

1.2.1 The components of the machine are listed in the packing list.

1.2.2 Product performance and structure

Ultrasonic scaler is composed of elect circuit, water way and ultrasonic transducer.

1.2.3 Scope of application

Ultrasonic scaler UDS-N1 and UDS-N2 is used for the dental calculus elimination.

### 1.3 The main technical specifications

1.3.1 Technical specifications of ultrasonic scaler

a) Power input:

With transformer 220 - 240V~ 50Hz/60Hz 150mA

Without transformer 24V~ 50Hz/60Hz 1.3A

b) Output primary tip Vibration excursion:  $\leq 100\mu\text{m}$

c) Output half-excursion force:  $< 2\text{N}$

d) Output tip vibration frequency: UDS-N1:  $30\text{kHz}\pm 3\text{kHz}$   
UDS-N2:  $28\text{kHz}\pm 3\text{kHz}$

e) Output power: 3W to 20W

f) Water pressure: 0.01MPa to 0.5MPa

g) Weight of main unit: 0.2kg

h) Main unit fuse: T1.6AL 250V

i) Weight of transformer: 1kg (optional)

j) Operating mode: Continuous operation

k) Type of protection against electric shock: Class II equipment

l) Degree of protection against electric shock: Type BF equipment

m) Degree of protection against harmful ingress of water: Ordinary equipment (IPX0)

n) Protection degree against water(used on the pedal): IPX1

o) Applied part of the equipment: handpiece and tip

p) Degree of safety of application in the presence of a flammable anesthetic mixture with air or with oxygen or nitrous oxide: Equipment can not be used in the presence of a flammable anesthetic mixture with air or with oxygen or nitrous oxide.

1.3.2 Working condition

- a) Environment temperature: +5°C to +40°C
- b) Relative humidity: 30% ~75%
- c) Atmosphere pressure: 70kPa to 106kPa
- d) A temperature of the water at the inlet: not higher than +25°C

1.4 Installing and connecting of the components

1.4.1 The installing and connecting illustration of the equipment's components are showed as picture 1:

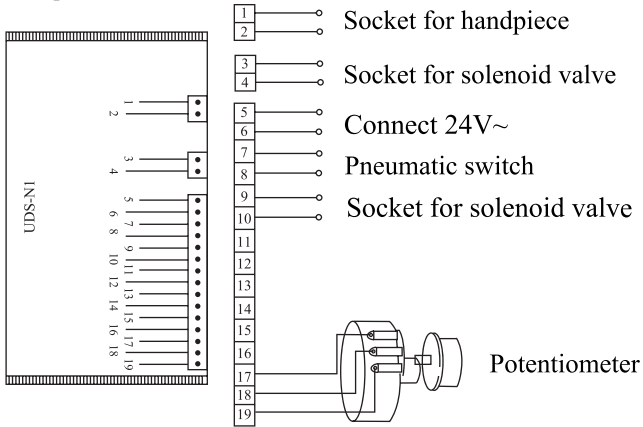

picture 1 a)

Notice:

- a) Please connect power supply and pneumatic switch (or foot pedal) as picture 1 a) showed.
- b) Lead No.5 and lead No.6 should be connected with 24V~,and this circuit is disallowed to act as switch circuit.
- c) Lead No.7 and lead No.8 should be connected with pneumatic switch (or foot switch) directly, and this circuit acts as switch circuit and is disallowed to do the short circuit.

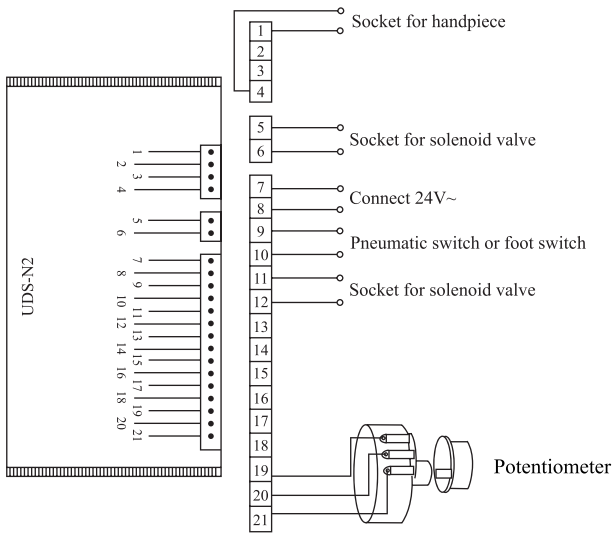

Picture 1 b)

Notice:

- Please connect power supply and pneumatic switch (or foot pedal) as picture 1 b) showed.
- Lead No.7 and lead No.8 should be connected with 24V~, and this circuit is disallowed to act as switch circuit.
- Lead No.9 and lead No.10 should be connected with pneumatic switch (or foot switch) directly, and this circuit acts as switch circuit and is disallowed to do the short circuit.

1.4.2 The followings should be noticed during installation.

- Pneumatic power switch, pneumatic penstock and pneumatic foot switch are equipped by manufacturers of the dental unit or the end-users.
- The manufacturers of dental unit, the dealers or end-users of the equipment need to dig holes in salver of dental unit so as to fix potentiometer and fetch out the silica gel pipe of handpiece cable.
- Be care the proper space for dispersing heat of ultrasonic generator.
- Built-in ultrasonic scaler without transformer occupies a less space ,and works with current 24V~, power $\geq$ 20W.
- Turn the potentiometer knob to the minimum and the water control switch the maximum before turning on the scaler.
- The frequency of ultrasonic scaler is extremely high. Under normal water supply, a light touch and a certain to-and-fro motion will eliminate the tartar without obvious heat. Overexertion and longtime lingering are forbidden.

## 2. Product function and usage

### 2.1 Working principle

2.1.1 Summarization: the built-in ultrasonic scaler is consist of ultrasonic generator (circuit), cable, handpiece (transformer), scaling tip, pneumatic switch (the power switch of pneumatic penstock and the circuit's commutating and filtering, is controlled by pneumatic foot pedal of dental unit and switch for handpiece rack of ultrasonic scaler at the same time) and switch for handpiece rack (it controls the air supply which gets through pneumatic penstock and pneumatic power switch. And the air supply is off when handpiece is in the rack and on when handpiece out).

2.1.2 Chart of working principle:

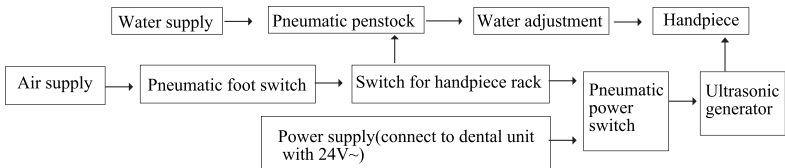

The air supply is on when the handpiece is out from the rack. Step on the foot switch, pneumatic power switch, pneumatic penstock, ultrasonic generator, handpiece and scaling tip all start working at the same time, and water supply is open.

### 2.2 Scaling function

2.2.1 Instruction of wrench (UDS-N1)

- Screw the tip on the handpiece.
- Make the tip inside the wrench's hole.
- Screw or unscrew the tip as picture 2 showed.

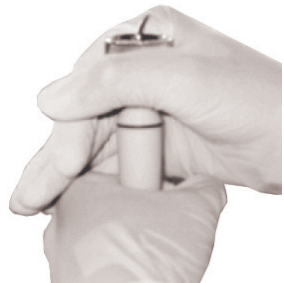

Picture 2

2.2.2 Instruction for main components of scaled and detachable handpiece (showed in picture 3)

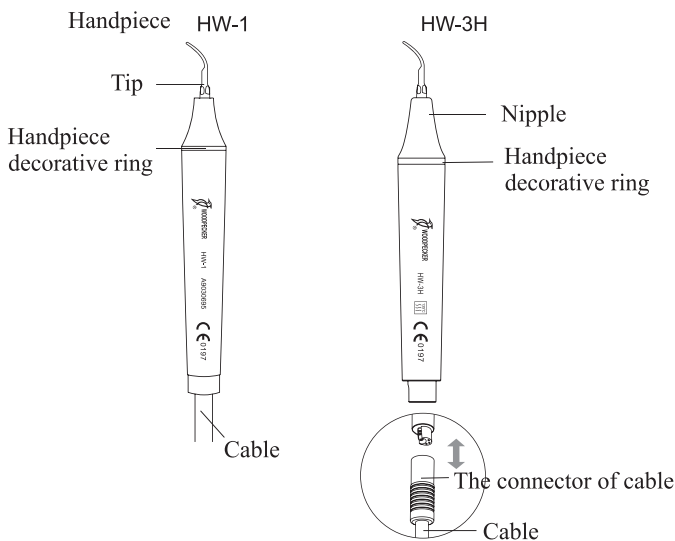

Picture 3

a) Nipple: The nipple can be removed. You can termly screw off the nipple and clean the pole with alcohol.

b) Decorative ring: can be disassembled and cleaned with alcohol regularly, can be autoclaved under the high temperature and pressure.

c) Handpiece: The main part of the whole handpiece, can be autoclaved under the high temperature and pressure.

d) Symbol:Denote that “Can be autoclaved to the high temperature (134°C) and the high pressure(0.22MPa)”.

e) The connector of the cable: Connect the handpiece with water source and power supply of the main unit.

### 2.2.3. Instruction for torque wrench (UDS-N2) (showed in picture 4)

a) The torque wrench is designed specially, which can control the strength for the scaling tip installation reasonably, guarantee that the operator can screw or unscrew the scaling tip effectively, and keep the hand away from hurting.

b) Operation

Take the tip into the torque wrench as picture 5 showed.

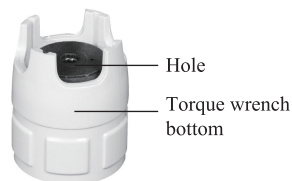

Picture 4

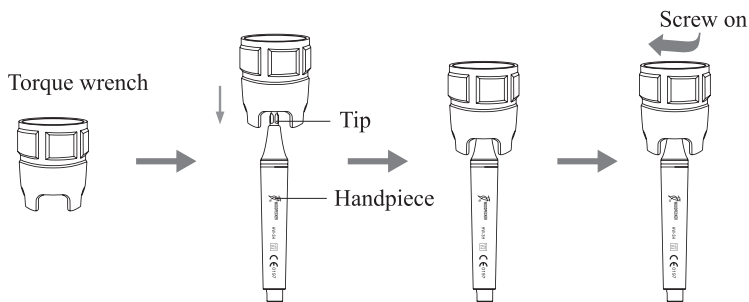

Picture 5

#### 2.2.4 Instruction for cutting sleeve (UDS-N2) (showed in picture 7)

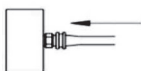
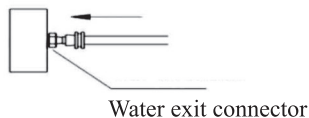
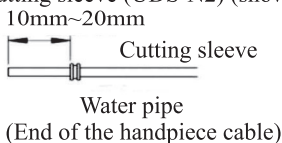

Picture 7

a) Put the cutting sleeve forward the water pipe, keep it 10mm~20mm from the front.

b) Put the water pipe in the middle of the water connector (about 3mm), then push the cutting sleeve forward the front of the water connector.

c) Pinch the cutting sleeve and the water pipe with your finger, push them forward simultaneously until they are fully wrapped into the water connector and the cutting sleeve in the middle of the water connector.

**Notice: Cut off the forepart of the water pipe about 6mm if repeat the above operation.**

#### 2.2.5 Scaling function and usage

a) After installation is completed, through the dental unit can realize the function adjustment and usage.



b) Select a suitable scaling tip as you need, screw it on the handpiece tightly by the torque wrench.

c) Through the dental unit to start the scaling function.

d) The handpiece can be handled in the same gesture as a pen in hand.

e) The frequency of ultrasonic scaler is extremely high. Under normal working state of the scaling tip, a light touch and a certain to-and-fro motion will eliminate the tartar without obvious heat. Overexertion and longtime lingering are forbidden.

f) During the clinical treatment, be sure not to make the end of tip touch the teeth vertically and not to make the tip overexert on the surface of the teeth in case of hurting the teeth and damaging the tip.

g) Under the support of dental unit, the vibration intensity and water can be adjust.

h) After finishing operation, keep the machine working for 30 seconds on the water supply condition in order to clean the handpiece and the scaling tip. Then unscrew the tips and handpiece to sterilization.

### **3. Sterilization and maintenance**

#### 3.1 Sterilization of tips and wrench

All the scaling tips ,wrench can be autoclaved, under high temperature, pressure, time: 134°C, 2.0bar~2.3bar (0.20MPa~0.23MPa), 4min.

#### 3.2 The scaling tip and wrench can be cleaned by ultrasonic cleaner.

#### 3.3 Handpiece can be sterilized by any neutral sterilized liquid for cleaning and sterilizing. Do not sterilize under the high temperature and pressure.(UDS-N1)

#### 3.4 Sterilization of detachable handpiece(UDS-N2)

3.4.1 Autoclaved under high temperature, pressure, time:

134°C, 2.0bar~2.3bar (0.20MPa~0.23MPa), 4min.

3.4.2 Pull out the handpiece and unscrew the tip after operation.

3.4.3 Pack the handpiece with steriled gauze or steriled bag before sterilization.

3.4.4 Reuse handpiece after it cools naturally in case of getting scald.

3.4.5 Notice:

a) Clear the cleaning liquid in the handpiece with compressed air before sterilization.

b) Be sure that the scaling tip has been unscrewed from the handpiece. Don't sterilize them together with other components.

c) Please check whether the handpiece's exterior has been damaged during the operation or sterilization. Don't smear any protective oil on the surface of handpiece.

d) There are two waterproof "O" rings at the end of the handpiece. Please

lubricate them with dental lube frequently, as sterilization and pulling and inserting repeatedly will reduce their using life. Change it once it is damaged or worn excessively.

- e) The following sterilizing methods are forbidden:
  - ① Boiled in the liquid.
  - ② Dip in disinfectant such as iodine, alcohol and glutaraldehyde.
  - ③ Baked in the normal oven or microwave oven.

### 3.5 Sterilization of torque wrench (UDS-N2)

3.5.1 The torque wrench can be sterilized by neutral non-corrosive disinfectant, or be sterilized under the high temperature and pressure.

3.5.2 The following sterilizing methods are forbidden:

- a) Boiled in liquor;
- b) Dip in disinfectant such as iodine, alcohol and glutaraldehyde;
- c) Baked in the normal oven or microwave oven.

**Notice: We are not responsible for any damage directly or indirectly made by any way in the above items to handpiece or torque wrench.**

### 3.6 Clean of tips and torque wrench (UDS-N2)

The scaling tips and torque wrench can be cleaned by ultrasonic cleaner.

### 3.7 Troubleshooting and notes

Fault	Possible causes	Solutions
The scaling tip doesn't vibrate when stepping on the foot switch	The plug is in loose or wrong contact.	Connect as picture 1 showde.
	Handpiece and the connector of cable are connected irrelevantly. (UDS-N2)	Pull out handpiece and insert it again.
	Scaling tip is loose.	Screw it on tightly with torque wrench.
	There is some water between the handpiece and the connector of cable. (UDS-N2)	Dry the connect point.
	There is something wrong with detachable handpiece. (UDS-N2)	Send it to our company to repair.
The scaling tip vibrates, but there is no water flowing out.	Water supply of dental unit is off.	Check the water supply of the dental unit.
	There is no water coming from the cable (UDS-N2).	Clean the water pipe of the cable with multi-function syringes.
	There is no water coming from the handpiece.	Clean the water line of the handpiece with multi-function syringes.
The handpiece generates heat.	The amount of spouting water is too little.	Turn the water control switch to a higher grade.
The amount of spouting water is too little.	The water pipe of dental unit is jammed.	Clean the water pipe.

Fault	Possible causes	Solutions
The amount of spouting water is too little.	The water pipe of cable is jammed (UDS-N2).	Clean the water pipe of the cable with multi-function syringe.
	The water pipe of handpiece is jammed.	Clean the water pipe of the handpiece with multi-function syringe.
	The water pressure is not high enough.	Enhance the water pressure.
The vibration of the tip becomes weak.	The tip hasn't been screwed tightly.	Screw the scaling tip tightly.
	The tips too loose which caused by vibration.	Screw the scaling tip tightly.
	The tip is damaged.	Change a new one.
The potentiometer is failure.	The potentiometer is damaged.	Change a new one.
There is water seeping from the joint of the handpiece and cable.	The waterproof "O" ring is damaged (UDS-N2).	Change a new one.

If the problem does still exist, please contact with local dealer or manufacturer.

#### **4. Notice**

##### 4.1 Notice when using equipment

4.1.1 Keep the scaler clean before and after operation.

4.1.2 The handpiece, scaling tip and torque wrench must be sterilized before operation.

4.1.3 Don't screw or unscrew the tip when stepping on the foot pedal.

4.1.4 The tip must be fastened and must be fine spray or drip coming from the tip when operation.

4.1.5 Change it when the tip is damaged or worn excessively. Don't twist the tip or rub it.

4.1.6 While scaler working ,the heat of scaling tip will become higher if there is no water flowing out.Please keep the water flow smoothly.

4.1.7 Don't use impurity water and don't use normal brine instead of purity

water.

4.1.8 Keep the connector of handpiece and the socket of the cable dry before installing the handpiece. (UDS-N2)

4.1.9 Don't pull the cable forcibly in case of the handpiece falling off the cable. (UDS-N2)

4.1.10 The internal screw thread of the scaling tips, produced by some other manufactures, is coarse, rusty and collapsed. This will damage the external screw thread of the handpiece irretrievably. Please use "WOODPECKER" brand scaling tips.

4.1.11 Make sure that the output voltage is 24V~ before connecting the built-in ultrasonic scaler with the power supply, in case of connecting to wrong power supply and make the unit burned.

4.1.12 Manufacturers of dental unit or the end-user are disallowed to disconnect the built-in ultrasonic scaler, in case of influencing the function of scaler. If you have any special request, please contact with our company.

4.1.13 Please select a suitable power when using different type of tips (refer to "TABLE OF OPERATING POWER OF THE TIPS").

#### 4.2 Contraindication

4.2.1 The hemophilia patient is forbidden to use this equipment.

4.2.2 The patients or doctors with heart pacemaker are forbidden to use this equipment.

4.2.3 The heart disease patient, pregnant woman and children should be cautious to use the equipment.

#### 4.3 Storage and maintenance

4.3.1 The equipment should be handled carefully and lightly. Be sure that it is far from the vibration, and installed or kept in a cool, dry and ventilated place.

4.3.2 Don't store the machine together with the articles that is combustible, poisonous, caustic, or explosive.

4.3.3 This equipment should be stored in a room where the relative humidity is 10% ~ 93%, atmospheric pressure is 70kPa to 106kPa, and the temperature is -20°C ~ +55°C.

4.3.4 If not be use, please turn off the power supply. If not be use for a long time, please make the machine get through the electricity and water once per month for five minutes.

#### 4.4 Transportation

4.4.1 Excessive impact and shake should be prevented during the transportation. Lay it carefully and lightly.

4.4.2 Don't put it together with dangerous goods during transportation.

4.4.3 Avoid solarization and getting wet in rain or snow during transportation.

#### 4.5 Manufacturer's rights

We reserve the right to change the design of the equipment, the technique, fittings, the instruction manual and the content of the original packing list at any time without notice.

## 5. After-service

Two years' warranty for the main unit, one year's warranty for the other spare parts (except the expendable parts) from the date of purchase.

As a professional manufacturer of medical instruments, we are only responsible for the product safety on the following conditions:

a) The maintenance, repair and modify are made by the manufacturer or the authorized dealer;

b) The exchanged components are original of "WOODPECKER" and operated according to instruction manual.

The repair of the equipment should be carried out by our professional technician. We are not responsible for any irretrievable damage caused by the non-professional person.

## 6. Environmental Protection

Please dispose according to the local laws.

## 7. European authorized representative



MedNet GmbH  
Borkstrasse 10 · 48163 Muenster · Germany

## 8. Manufacturer's right

We reserve the rights to change the design of the equipment, the technique, fittings, the instruction manual and the content of the original packing list at any time without notice. If there are some differences between blueprint and real equipment, take the real equipment as the norm.

## 9. Symbol instruction



Trademark



Used indoor only



Consult the accompanying documents



Appliance compliance  
WEEE directive



Class II equipment



Alternating current



Type BF applied part



Authorised Representative  
in the EUROPEAN  
COMMUNITY



Recovery



Date of manufacture



Can be autoclaved



Manufacturer



Atmospheric pressure for  
storage



Humidity limitation for  
storage



Temperature limitation for  
storage



Ordinary equipment



CE marked product



FDA marked product



Handle with care



Keep dry

## 10. EMC - Declaration of conformity

<b>Guidance and manufacturer's declaration - electromagnetic emissions</b>		
The model UDS-N1, UDS-N2, UDS-N3, UDS-N2 LED, UDS-N3 LED, V1, V2, V3, V2 LED, V3 LED are intended for use in the electromagnetic environment specified below. The customer or the user of the model UDS-N1, UDS-N2, UDS-N3, UDS-N2 LED, UDS-N3 LED, V1, V2, V3, V2 LED, V3 LED should assure that it is used in such an environment.		
<b>Emissions test</b>	<b>Compliance</b>	<b>Electromagnetic environment - guidance</b>
RF emissions CISPR 11	Group 1	The models UDS-N1, UDS-N2, UDS-N3, UDS-N2 LED, UDS-N3 LED, V1, V2, V3, V2 LED, V3 LED use RF energy only for its internal function. Therefore, its RF emissions are very low and are not likely to cause any interference in nearby electronic equipment.
RF emissions CISPR11	Class B	The models UDS-N1, UDS-N2, UDS-N3, UDS-N2 LED, UDS-N3 LED, V1, V2, V3, V2 LED, V3 LED are suitable for used in domestic establishment and in establishment directly connected to a low voltage power supply network which supplies buildings used for domestic purposes.
Harmonic emissions IEC 61000-3-2	Class A	
Voltage fluctuations / flicker emissions IEC 61000-3-3	Complies	

<b>Guidance &amp; Declaration — electromagnetic immunity</b>			
The models UDS-N1, UDS-N2, UDS-N3, UDS-N2 LED, UDS-N3 LED, V1, V2, V3, V2 LED, V3 LED are intended for use in the electromagnetic environment specified below. The customer or the user of the models UDS-N1, UDS-N2, UDS-N3, UDS-N2 LED, UDS-N3 LED, V1, V2, V3, V2 LED, V3 LED should assure that it is used in such an environment.			
<b>Immunity test</b>	<b>IEC 60601 test level</b>	<b>Compliance level</b>	<b>Electromagnetic environment - guidance</b>
Electrostatic discharge (ESD) IEC 61000-4-2	±6 kV contact ±8 kV air	±6 kV contact ±8 kV air	Floors should be wood, concrete or ceramic tile. If floors are covered with synthetic material, the relative humidity should be at least 30 %.
Electrical fast transient/burst IEC 61000-4-4	±2kV for power supply lines ±1 kV for Input/output lines	±2kV for power supply lines ±1kV for interconnecting cable	Mains power quality should be that of a typical commercial or hospital environment.
Surge IEC 61000-4-5	±1 kV line to line ±2 kV line to earth	±1 kV line to line	Mains power quality should be that of a typical commercial or hospital environment.
Voltage dips, short interruptions and voltage variations on power supply input lines IEC 61000-4-11.	<5 % $U_T$ (>95% dip in $U_T$ ) for 0.5 cycle 40 % $U_T$ (60% dip in $U_T$ ) for 5 cycles 70% $U_T$ (30% dip in $U_T$ ) for 25 cycles <5% $U_T$ (>95 % dip in $U_T$ ) for 5 sec	<5 % $U_T$ (>95% dip in $U_T$ ) for 0.5 cycle 40 % $U_T$ (60% dip in $U_T$ ) for 5 cycles 70% $U_T$ (30% dip in $U_T$ ) for 25 cycles <5% $U_T$ (>95 % dip in $U_T$ ) for 5 sec	Mains power quality should be that of a typical commercial or hospital environment. If the user of the models UDS-N1, UDS-N2, UDS-N3, UDS-N2 LED, UDS-N3 LED, V1, V2, V3, V2 LED, V3 LED require continued operation during power mains interruptions, it is recommended that the models UDS-N1, UDS-N2, UDS-N3, UDS-N2 LED, UDS-N3 LED, V1, V2, V3, V2 LED, V3 LED be powered from an uninterruptible power supply or a battery.
Power frequency (50/60 Hz) magnetic field IEC 61000-4-8	3 A/m	3 A/m	Power frequency magnetic fields should be at levels characteristic of a typical location in a typical commercial or hospital environment.
NOTE $U_T$ is the a.c. mains voltage prior to application of the test level.			



**Guidance & Declaration - Electromagnetic immunity**

The models UDS-N1, UDS-N2, UDS-N3, UDS-N2 LED, UDS-N3 LED, V1, V2, V3, V2 LED, V3 LED are intended for use in the electromagnetic environment specified below. The customer or the user of the models UDS-N1, UDS-N2, UDS-N3, UDS-N2 LED, UDS-N3 LED, V1, V2, V3, V2 LED, V3 LED should assure that it is used in such an environment.

Immunity test	IEC 60601 test level	Compliance level	Electromagnetic environment - guidance
Conducted RF IEC 61000-4-6 Radiated RF IEC 61000-4-3	3 Vrms 150 kHz to 80 MHz 3 V/m 80 MHz to 2.5 GHz	3V  3 V/m	Portable and mobile RF communications equipment should be used no closer to any part of the models UDS-N1, UDS-N2, UDS-N3, UDS-N2 LED, UDS-N3 LED, V1, V2, V3, V2 LED, V3 LED, including cables, than the recommended separation distance calculated from the equation applicable to the frequency of the transmitter. <b>Recommended separation distance</b> 3V $d=1.2 \times P^{1/2}$ 80 MHz to 800 MHz $d=2.3 \times P$ 800 MHz to 2.5 GHz where <i>P</i> is the maximum output power rating of the transmitter in watts (W) according to the transmitter manufacturer and <i>d</i> is the recommended separation distance in meters (m). Field strengths from fixed RF transmitters, as determined by an electromagnetic site survey, <sup>a</sup> should be less than the compliance level in each frequency range. <sup>b</sup> Interference may occur in the vicinity of equipment marked with the following symbol: 

NOTE 1 At 80 MHz end 800 MHz. the higher frequency range applies.

NOTE 2 These guidelines may not apply in all situations. Electromagnetic propagation is affected by absorption and reflection from structures, objects and people.

<sup>a</sup> Field strengths from fixed transmitters, such as base stations for radio (cellular/cordless) telephones and land mobile radios, amateur radio, AM and FM radio broadcast and TV broadcast cannot be predicted theoretically with accuracy. To assess the electromagnetic environment due to fixed RF transmitters, an electromagnetic site survey should be considered. If the measured field strength in the location in which the models UDS-N1, UDS-N2, UDS-N3, UDS-N2 LED, UDS-N3 LED, V1, V2, V3, V2 LED, V3 LED are used exceeds the applicable RF compliance level above, the model UDS-N1, UDS-N2, UDS-N3, UDS-N2 LED, UDS-N3 LED, V1, V2, V3, V2 LED, V3 LED should be observed to verify normal operation. If abnormal performance is observed, additional measures may be necessary, such as reorienting or relocating the models UDS-N1, UDS-N2, UDS-N3, UDS-N2 LED, UDS-N3 LED, V1, V2, V3, V2 LED, V3 LED.

<sup>b</sup> Over the frequency range 150 kHz to 80 MHz, field strengths should be less than 3V/m.

Recommended separation distances between portable and mobile RF communications equipment and the models UDS-N1, UDS-N2, UDS-N3, UDS-N2 LED, UDS-N3 LED, V1, V2, V3, V2 LED, V3 LED			
The model UDS-N1, UDS-N2, UDS-N3, UDS-N2 LED, UDS-N3 LED, V1, V2, V3, V2 LED, V3 LED is intended for use in electromagnetic environment in which radiated RF disturbances is controlled. The customer or the user of the models UDS-N1, UDS-N2, UDS-N3, UDS-N2 LED, UDS-N3 LED, V1, V2, V3, V2 LED, V3 LED can help prevent electromagnetic interference by maintaining a minimum distance between portable and mobile RF communications equipment (transmitters) and the models UDS-N1, UDS-N2, UDS-N3, UDS-N2 LED, UDS-N3 LED, V1, V2, V3, V2 LED, V3 LED are recommended below, according to the maximum output power of the communications equipment.			
Rated maximum output power of transmitter W	Separation distance according to frequency of transmitter m		
	150kHz to 80MHz $d=1.2 \times P^{1/2}$	80MHz to 800MHz $d=1.2 \times P^{1/2}$	800MHz to 2,5GHz $d=2.3 \times P^{1/2}$
0,01	0.12	0.12	0.23
0,1	0.38	0.38	0.73
1	1.2	1.2	2.3
10	3.8	3.8	7.3
100	12	12	23
For transmitters rated at a maximum output power not listed above, the recommended separation distance $d$ in meters (m) can be estimated using the equation applicable to the frequency of the transmitter, where $P$ is the maximum output power rating of the transmitter in watts (W) accordable to the transmitter manufacturer.			
NOTE 1 At 80 MHz and 800 MHz. the separation distance for the higher frequency range applies.			
NOTE 2 These guidelines may not apply in all situations. Electromagnetic propagation is affected by absorption and reflection from structures, objects and people.			

The device has been tested and homologated in accordance with EN 60601-1-2 for EMC. This does not guarantee in any way that this device will not be effected by electromagnetic interference Avoid using the device in high electromagnetic environment.

## 11. Statement

All rights of modifying the product are reserved to the manufacturer without further notice. The pictures are only for reference. The final interpretation rights belong to GUILIN WOODPECKER MEDICAL INSTRUMENT CO., LTD. The industrial design, inner structure, etc, have claimed for several patents by WOODPECKER, any copy or fake product must take legal responsibilities.

**TABLE OF OPERATING POWER OF THE TIPS**

Scaling	
Tip Model	Power
G 1	LOW-HIGH
G 2	LOW-HIGH
G 3	LOW-HIGH
G 4	LOW-HIGH
G 5	LOW-HIGH
G 6	LOW-HIGH
G 7	LOW-HIGH
G 8	LOW-HIGH
G 9	LOW-HIGH
G 10	LOW-HIGH
G 11	LOW-HIGH

Periodontics	
Tip Model	Power
P1	LOW-MID
P2L	LOW
P2LD	LOW
P2R	LOW
P2RD	LOW
P3	LOW-MID
P3D	LOW-MID
P4	LOW-MID
P4D	LOW-MID

Endodontics	
Tip Model	Power
E1	--
E2	--
E3	--
E3D	--
E4	--
E4D	--
E5	--
E5D	--
E8	--
E9	--
E10	--
E10D	--
E11	--
E11D	--
E14	--
E15	--

Cavity Preparation	
Tip Model	Power
SB1	LOW-MID
SB2	LOW-MID
SB3	LOW-MID
SBL	LOW-MID
SBR	LOW-MID

Scan and Login website  
for more information



Guilin Woodpecker Medical Instrument Co., Ltd.  
Information Industrial Park, Guilin National High-Tech  
Zone, Guilin, Guangxi, 541004 P. R. China

Tel:

Europe Sales Dept.: +86-773-5873196, +86-773-2125222

North America, South America &

Oceania Sales Dept.: +86-773-5873198, +86-773-2125123

Asia & Africa Sales Dept.: +86-773-5855350, +86-773-2125896

Fax: +86-773-5822450

E-mail: [woodpecker@glwoodpecker.com](mailto:woodpecker@glwoodpecker.com), [sales@glwoodpecker.com](mailto:sales@glwoodpecker.com)

Website: <http://www.glwoodpecker.com>



MedNet GmbH

Borkstrasse 10 · 48163 Muenster · Germany